



Walschaerts Valve-Gear

This kit contains parts to construct a set of Walschaerts type valve-gear as used on **ROUNDHOUSE** locomotives. It is of a simplified design, which does not use a combination lever and is intended for use with the **ROUNDHOUSE** Cylinder set.

NOTE:- Frames, Cylinders, Coupling Rods, Connecting Rods, Axles and Outside Cranks are not included with this set of parts.



Roundhouse Engineering Co. Ltd

Units 6 to 9, Churchill Business Park,
Churchill Road, Wheatley,
Doncaster. DN1 2TF. England.

Tel 01302 328035 Fax 01302 761312

Email: mail@roundhouse-eng.com

www.roundhouse-eng.com

This pack contains the following parts: -

- 2 Return Cranks with steel screws & nuts.
 - 2 Expansion links with bushes & 2BA nuts.
 - 2 Lifting arms with grub screws & Allen key.
 - 2 Lifting links.
 - 4 M2 steel screws & nuts.
 - 6 5BA steel washers.
 - 2 Radius rods.
 - 2 Weigh shaft brackets
 - 1 Weigh shaft.
 - 2 Starlock washers
 - 2 Roll pins.
 - 6 Short crank pins.
 - 2 Plain crank pins
-
- 1 Push Rod Connector, Screw & Starlock.
 - 1 Stainless Steel spring & Long Crank Pin.
 - 1 Reversing lever handle.
 - 1 Reversing lever base.
 - 3 M2 screws and nuts.
 - 2 M3 mounting screws.
-
- 1 Steel push rod & quicklink connector.
 - 2 Eccentric rods.

Walschaerts Valve-Gear

Part Number WVG

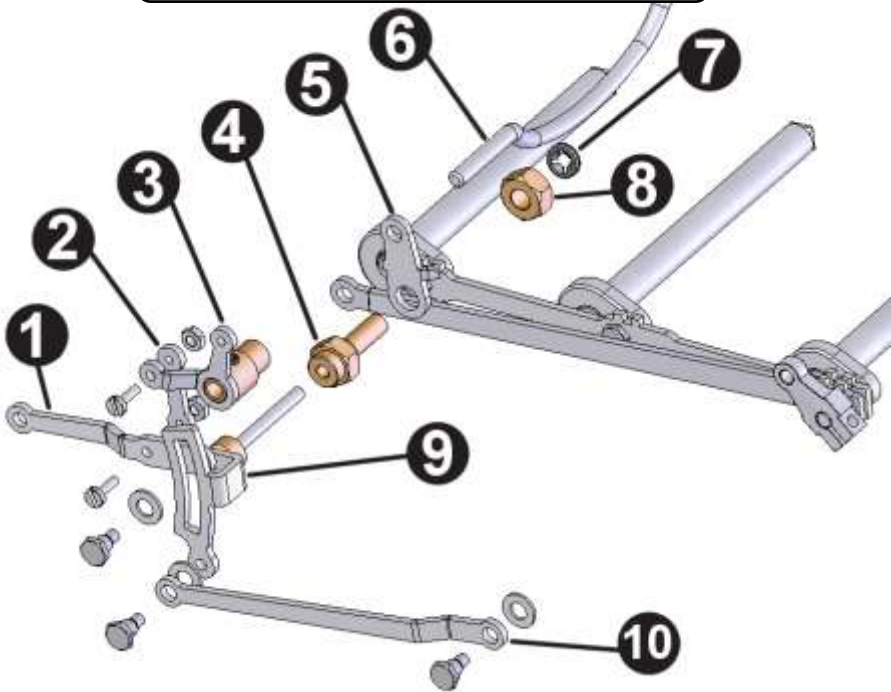

Assembly of Walschaerts type valve-gear

- 1). Radius Rod. 2). Lifting Link. 3). Lifting Arm.
- 4). Expansion Link Bush. 5). Weigh Shaft Bracket (Penguin).
- 6). Weigh Shaft. 7). Starlock Washer. 8). 2BA Nut.
- 9). Expansion Link. 10). Eccentric Rod.

Construction

If constructing your own frames, ensure that the rear axle hole, expansion link mounting hole and cylinder mounting holes are positioned accurately as in the diagram below. These instructions assume that a rolling chassis has been built, with cylinders, coupling, and connecting rods fitted and mounting holes drilled for expansion link bushes. Two plain crank pins are supplied for use in the rear driving axle outside cranks. These are threaded 6BA and are correct length for mounting the return cranks on if using 1/16" thick connecting and coupling rods. They should be 'loctited' into the outside cranks and the end of the thread, which has a small counterbore, riveted over on the back to hold firmly in place. Refer to the main diagram showing an exploded view of the left-hand valve gear. Although connecting and coupling rods and outside cranks are illustrated, these are for reference only and are not included in this kit.

Fit the return cranks first, as these will then retain the coupling and connecting rods. The positioning of these is critical to the correct running of the engine and when the valve-gear is all assembled and tested; they will be pinned in place to prevent any movement. For the moment however just clamp them in position using the 6BA steel screws and nuts provided. Refer to the diagram and note that the return crank always leads the crank pin in forward rotation.

The weigh shaft can now be assembled. Take one weigh shaft bracket or 'Penguin' bracket as they are commonly known at **ROUNDHOUSE** (use your imagination here) and push the threaded part of an expansion link bush through the larger (bottom) hole. Note that the smaller top hole is offset and when bolted to the frame, will be slightly in front of the expansion link pivot point. The two small 'wings' sticking out from the sides of the 'Penguin' brackets should be bent backwards a little with a pair of pliers. These will locate on the top face of the chassis to keep the bracket in position. Push the expansion link bush through the hole in the chassis and fit the brass 2BA nut on the inside. When tightened up, the 'Penguin' bracket is held tight against the outside of the frame with its 'wings' resting on the top edge and the top hole slightly forward.

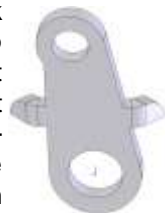

*Weigh
Shaft
Bracket*

Now slide one end of the weigh shaft through the top hole and repeat the procedure with the other side.

Before actually fitting the weigh shaft, it should be checked to see that the straight sections at each end are parallel to each other. This is easily done by holding a straight edge (steel ruler or similar), against it. If the ends are not parallel to the ruler, a little gentle hand bending will soon put it right.

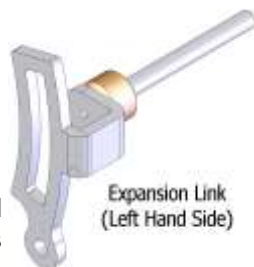

*Expansion Link
(Left Hand Side)*

The pivot pins on the expansion links can now be pushed through the bushes. Note that these are handed and, with the tapped hole to the bottom, the U-shaped extension, which connects the expansion link to its pivot pin, should be to the rear. Starlock washers are pushed onto the ends

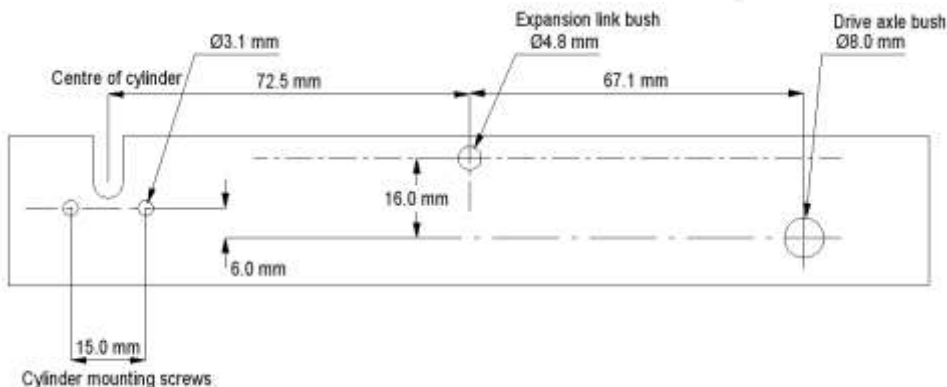

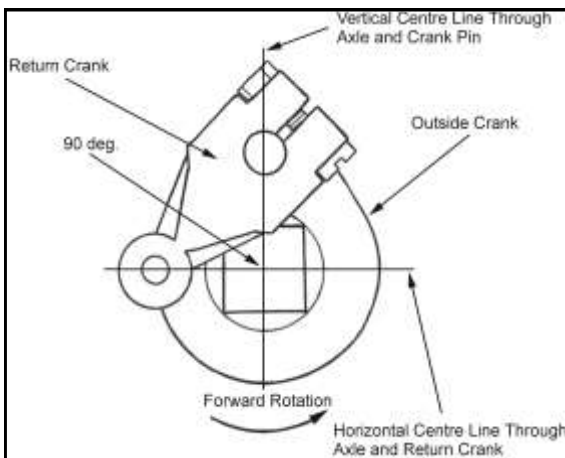

This diagram shows the left hand side return crank.

Right hand side is mirror image of this so that the return crank is still leading the crank pin by 90 degrees in forward rotation.

of the pivot pins between the frames to hold them in place, but should not be pushed on so far that they prevent free rotation.



The eccentric rods can now be fitted to connect the return cranks and the expansion links. These rods are slightly tapered and the thicker end has a 'joggle'. They are attached by 6BA shouldered crank pins with a washer between. The thicker end goes to the rear with the 'joggle' outwards.

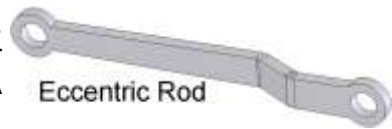

This is a good point to check that everything works freely when the wheels are rotated. Check for tight spots or anything not aligned correctly.

Now onto the radius rods.

Before fitting, the crank pins, which form the slide block in the expansion link, have to be prepared. This simply entails screwing one into the tapped hole in the thick end of the radius rod and filing off the excess thread, which sticks through at the rear. File the thread off flush to the back then remove the screw again.

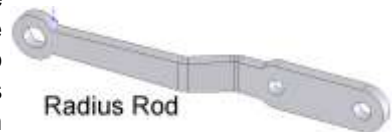

Take the prepared crank pin, fit a steel washer then pass it through the curved slot in the expansion link and screw it into the tapped hole in the radius rod. Note that the radius rod is also 'joggled'. This time the 'joggle' should be inwards to bring the thinner end of the radius rod nicely in line with the valve spindle on the cylinders.

Fit the thinner end into the forked end of the valve rod and screw the 6BA steel screw (supplied with the cylinders) through the hole to connect up. You now have the main links connected and rotating the wheels with the radius

rod at the bottom of the curved slot in the expansion link should result in the valve in the cylinders being moved backwards and forwards. What is needed now is a means of raising and lowering the radius rod and holding it in position so we now must assemble the lifting links etc.



Onto the left-hand end of the weigh shaft slide the left hand lifting arm. Note that the lifting arms are handed and the left hand has a second arm which points upwards and slightly forwards for attaching the reversing rod.

Using the M2 steel screws, connect the lifting arm to the radius rod. The screws pass through the holes in the arm and radius rod and screw into tapped holes in the lifting links. Do not tighten the screws, but leave a small gap to allow for movement as the lifting gear operates. Fit a M2 steel nut to the screws at the back of the lifting link and tighten these up.

The reversing rod and 'quicklink' can be used to hold things in position while they are fixed. Screw the 'quicklink' onto the end of the reversing rod and attach it to the lifting arm (the one pointing upwards on the left hand side) by springing the ends open, pushing the pin through the hole in the arm and then letting it close.

Set the valve-gear to mid gear, that is, operate the lifting arm until the hexagon screw, which drives the radius rod and slides up and down in the expansion link, is exactly in the centre of the curved slot. Check this by rotating the wheels and watching the radius rod. There should be no fore and aft movement whatsoever. Keeping it in this position, lightly clamp the end of the reversing rod to the side of the chassis with a small 'G' or toolmakers clamp. Double-check the position of the radius rod.

Now, turn the weigh shaft until the bow in it is at the bottom. This bow is to clear the underside of the boiler on some engines, and bear in mind that it will swing through a small arc as the valve gear is moved from forward to reverse. Clamp the arm in position by tightening the 4BA grub screw in the top of the lifting arm with the Allen key provided. If necessary, slacken the grub screw, reposition the lifting arm and re-tighten.

Keeping everything clamped in place, assemble the right hand lifting arm and link, and set that side to mid gear.

Hold the links in position and lock with grub screw as before.

Take great care with this operation and ensure that the radius rods on both sides are exactly in mid gear before, or they will be lifted unevenly when the lifting arms are operated.

The valve-gear is now assembled and we can move on to timing before finally pinning the return cranks in position.

Valve Timing

This is adjusting the valves so that they open and close at the correct time.

With the valve-gear still clamped in mid gear and the valve chest covers removed from the cylinders, look down into the valve-chests and note the position of the slide valves. They should be sitting centrally over the steam inlet ports, covering both. If they are not, disconnect the radius rod from the valve spindle fork end and rotate the valve spindle to screw the slide valve in the desired direction. Re-connect the radius rod and re-check position. There may be a small amount of fore and aft free movement of the valve if the spindle is moved with the fingers, which just uncovers the steam ports. If this is the case, adjust the valve position so that the ports are opened an equal amount when moved thus. Repeat this with both sides until the valves are correctly positioned.

Unclamp the end of the reversing rod and move it forward so that the radius rods are lowered in the expansion links. Position them near but not right at the bottom and clamp the reversing rod in place again. The gear is now set for forward running so, rotate the wheels by hand in a forward direction and watch the slide valve movement.

The edge of the steam ports should become visible (crack open) as the crank pin on the drive axle is at dead centre. The front steam port should be cracking open at front dead centre and the rear steam port at rear dead centre.

If the return cranks are correctly positioned, this should be the case. If not, rotate the return crank on the crank pin a very small amount and re-check.

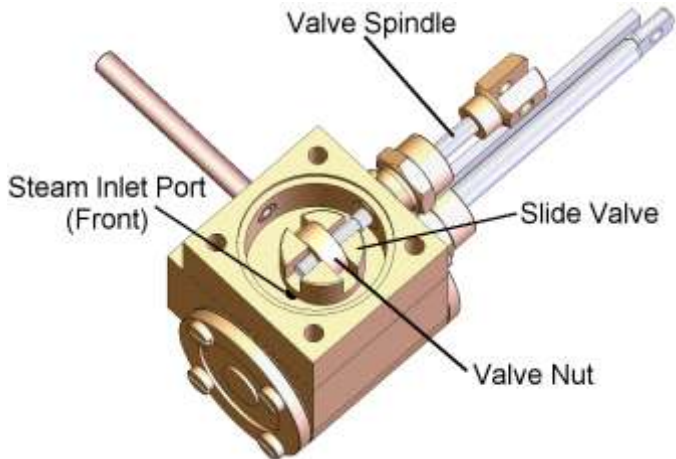

As an extra check to the correct positioning of the return cranks when using **ROUNDHOUSE** cylinders, you can check the dimensions as shown in diagram.

When satisfied that the timing is as close as you can get it, the chassis can be test run on compressed air, if available, to check operation. Don't forget that the radius rod should not be raised or lowered right to the ends of the expansion link slot, and use plenty of oil on all working parts. Slight unevenness in running can normally be overcome by slight adjustments when the locomotive is run-

ning under its own steam, see fine-tuning.

Finally, the return cranks should be drilled and pinned to ensure that they do not move in service.

Place the chassis on the worktop and rotate the wheels to position the outside cranks towards the top of its movement, with one of its sides sitting horizontal. Place a 3/4" thick block of wood underneath the return crank to support it.

Using a sharp 1.6mm drill, drill a hole vertically downwards through the centre of the return crank, through the crank pin, and out of the bottom. Push a roll pin through this hole to lock this side in place, and then repeat for the other side.

Ensure that the return cranks do not move during this operation.

Reversing Lever

A set of parts are included to construct a reversing lever for manual operation that can be mounted on the footplate. Refer to the diagram below which shows how the reversing lever is assembled. Check that the Reversing Lever Arm is orientated as shown in the diagram below. Then attach the push rod connector to the Reversing Lever Arm with the Starlock Washer as shown. Place the spring over the Long Crank Pin and push the threaded end of the Long Crank Pin through the hole in the bottom of the Reversing Lever Arm and screw into the threaded hole in the Reversing Lever Base. Fit a M2 screw and nut to the top central hole in the Reversing Lever Base which will allow the Lever to stay at mid gear. Now fit a M2 screw and nut to either side of the lever. This will allow you to move the valve gear between Forward, Reverse and Mid-Gear. The

exact position of these screws can be determined by running the chassis or loco on blocks and moving the lever as it is running until the optimum position is found.

The assembly should be securely fixed to the chassis or footplate using the M3 brass screws so that the valve-gear is held firmly in gear. The reversing lever should be fitted so that the reversing lever arm and the push rod connector are facing towards the inside of the cab - they will foul on the cab side if fitted the other way around. If a **ROUNDHOUSE** body kit is to be used, mounting holes are provided on the cab footplate so, to test run the chassis at this stage, simply clamp the end of

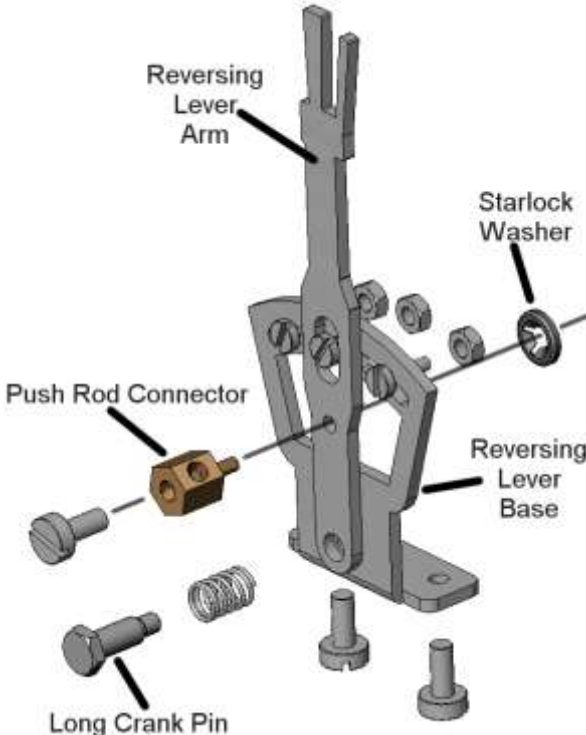

the reversing rod to the chassis as previously described.

Adjust the lever for smoothest running in both forward and reverse then tighten the stops accordingly.

Fine Tuning

When the locomotive is capable of running on the track under its own steam, the timing can be fine-tuned for best performance.

Set the loco off on a reasonably level length of track at a slow speed. If it stalls, note the position of the drive crank pins and if either is at front or rear dead centre. Repeat this several times and it will soon show up if there is a 'dead spot' at any particular point of the valve cycle. If, for instance, it keeps stalling with one particular crank pin just after rear dead centre, then this would indicate that the slide valve is opening a little late. Disconnect the radius rod and rotate the valve spindle half a turn to move the slide valve forward a fraction as detailed in valve timing earlier. Reconnect the radius rod and try the loco again in both directions to check that your adjustment has not simply removed that dead spot only to replace it one in a different position. A short time spent running the engine and making adjustments of just half a turn of the valve spindle at a time should soon show its optimum positions.



Radio Control

This valve-gear is ideal for operation by radio control; however, a suitable horn must be fitted to the servo, which gives a very short movement.

Remember that the radius rod does not move the full length of the expansion link between forward and reverse and a little trial and effort is needed to match this movement to that of the servo.

