

**LA1
Semaphore Signal Kit**

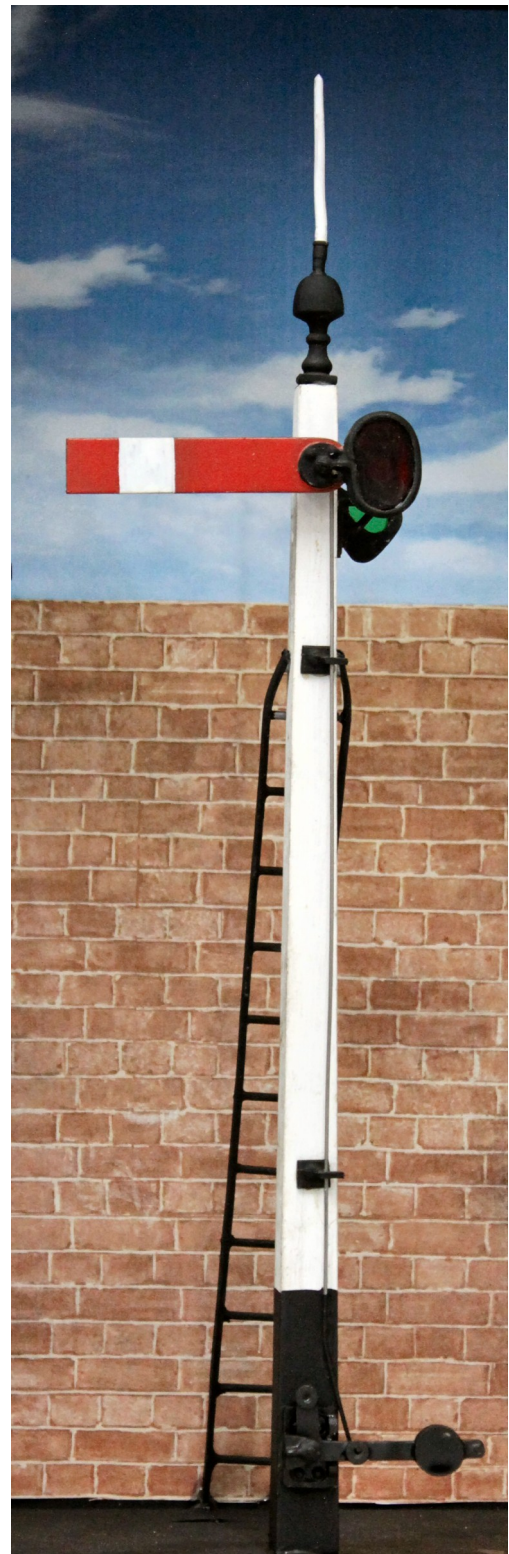

**McKenzie & Holland Signal as used on
the Ffestiniog Railway.
Requires assembling and painting.**

**Roundhouse Engineering Co. Ltd.
Churchill Business Park
Churchill Road, Wheatley,
Doncaster. DN1 2TF.
Phone 01302 328035 Fax 01302 761312
www.roundhouse-eng.com**

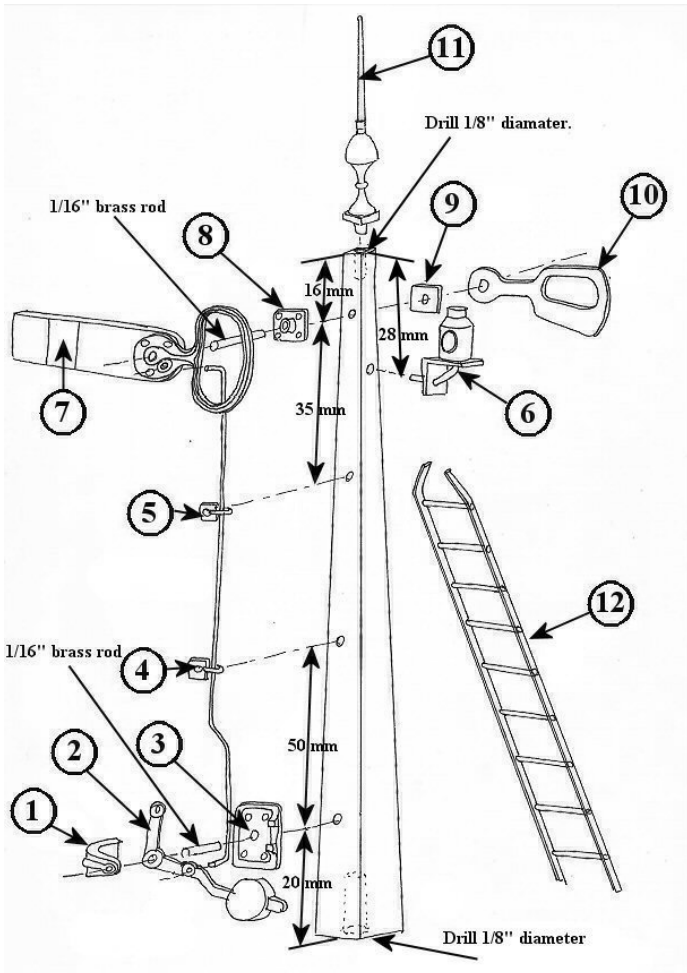
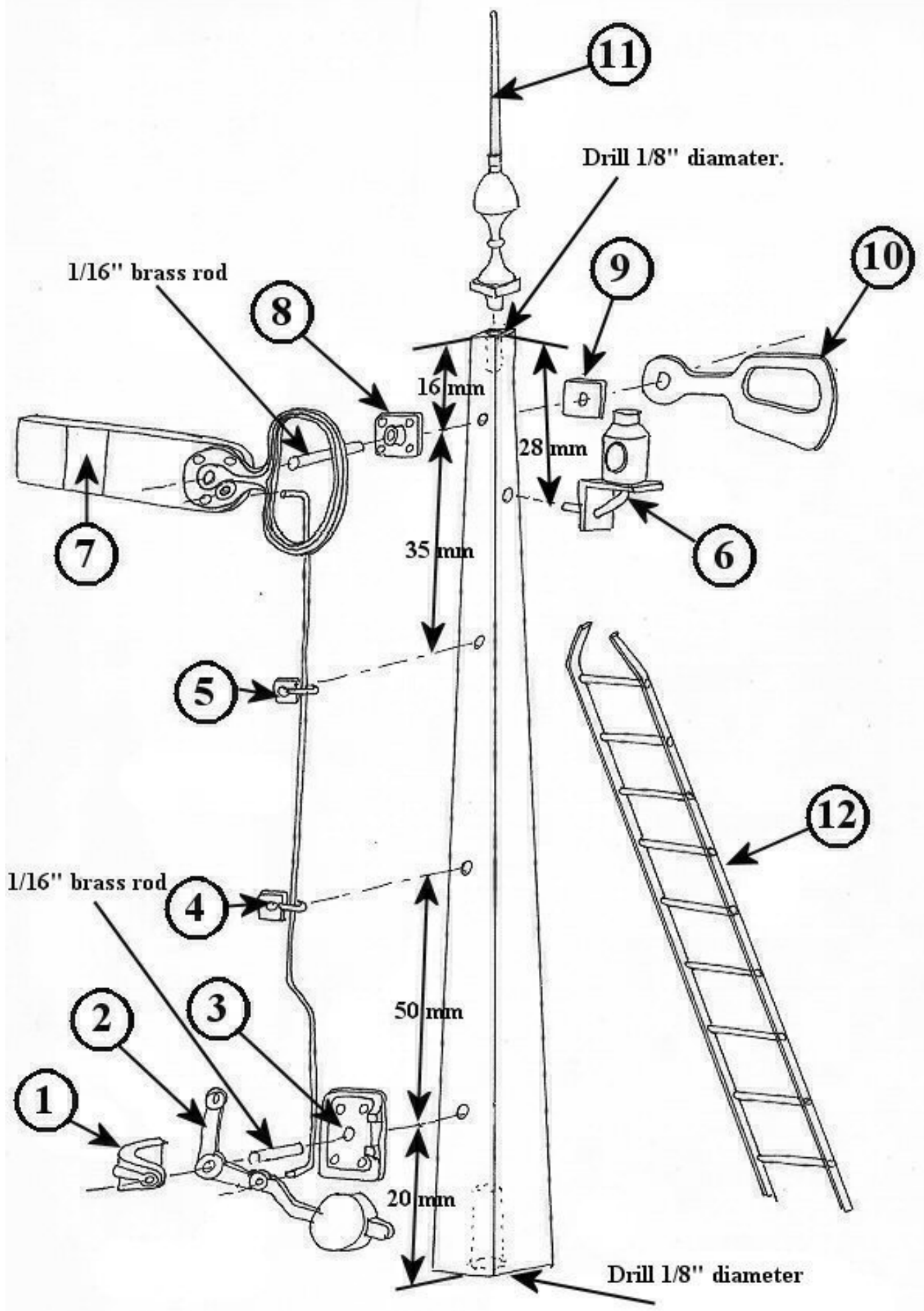

Instructions for LA1 Semaphore Signal Kit

Before starting construction, read through these instructions carefully and have a dry run with the parts to check that all is well. The metal castings should be treated with respect as rough handling could cause damage. If any castings are bent, they can be straightened carefully by hand, but do not use excessive force. Any item found to be faulty should be returned to the manufacturer for replacement.

This kit consists of

12 white metal castings.

1 tapered wooden post.

1 piece of red plastic glazing.

1 piece of green plastic glazing.

1 length of stainless steel wire.

1 length of 1/16" diameter brass rod.

Carefully clean all parts, removing mould lines and flash with a sharp craft knife and small file.

Mark out and drill the wooden post as follows, see diagram for clarification..

In the centre of each end, drill 1/8" diameter holes. The top hole (thinnest end) is to locate the cast metal finial and the bottom, (fattest end) is for a mounting rod.

On one side, drill four 1/16" diameter holes. The first is 16mm from the top and should go right through the post as this is for the semaphore arm and rear spectacle. The second hole is 35mm below the first and should only go about half way through the post.

A third hole, 20mm from the bottom of the post and a fourth one, 50mm above that, both of which should also, only go about half way through the post.

Drill a final hole on the right hand side of the post, 28mm from the top, half way through the post.

Mark out and cut the spectacle glazing to shape.

The easiest way to do this is to put a thin coat of paint on the raised rim of the two spectacles and press them onto their respective colour film to impress a mark of the outline. The plastic sheet can then be cut to this shape so that they fit inside their spectacle rims.

Note that the front spectacle on the end of the semaphore arm (part 7) is red and the rear one (part 10) is green.

It is better if all the parts are painted before assembly.

The post is white with bottom 2" in black.

The finial (part 11) is black with a white spike.

The semaphore arm (part 7) is red with a white stripe on the front, and white with a black band on the rear. The boss and spectacle frame are black. The front is the side with the spectacle and boss with raised rivet detail.

All the other metal castings are black.

Once the paint has dried, the spectacle glazing can be carefully glued into the spectacle frames.

Glue parts 8 and 9 to opposite sides of the post, aligning them with the hole drilled 16mm from the top of the post. Once the glue has set, carefully pass a 1/16" drill right through to clean out the hole of any surplus glue.

Cut a piece of the 1/16" diameter brass rod approximately 15mm long and push it into the hole in the signal post that is 20mm up from the bottom, leaving 8mm sticking out of the post.

Glue part 3 to the post, over the brass rod you have just fitted, with the two lever stops to the right hand side.

Once the glue has set, place part 2 over the brass rod with the weight arm pointing out to the right.

Part 1 slips over the top of the rod to retain the operating arm. Carefully, glue the back edge of part 1 to the left hand side of part 2 then apply a small amount of glue to the outer face of part 1 to fix it to the end of the brass rod. Ensure that no glue gets into the pivot of part 2 as it must move freely between the two lever stops on part 3.

Cut a piece of the 1/16" diameter brass rod approximately 28 mm long and glue the semaphore arm (part 7) to one end so that the rod sticks out from the rear.

When the glue has set, pass the brass rod through the castings and hole 16mm from the top of the post and carefully glue the rear spectacle to the other end of the rod. The two parts should be positioned so that the centre of the two spectacles are on the same centre line. Leave to set.

Using the stainless steel wire, bend one end at 90 degrees, approximately 8mm from the end. This will fit into the hole in the semaphore arm boss.

The wire then runs vertically downwards, to the right of centre of the post to approximately 30mm above the operating arm. It then requires a small kink, out to the right, to bring it in line with the hole in the operating arm.

Set the semaphore arm horizontal and pointing to the left, and set the operating arm/balance weight at it's lowest position between the two stops.

Mark the point at which the wire corresponds to the hole in the operating arm and form a 90 degree bend here to pass through this hole.

Check that when the operating arm/balance weight is lifted, the semaphore arm drops approximately 45 degrees.

When you are satisfied that the wire is correctly formed and operating correctly, disconnect the bottom end and slide the two guides (part 4 & 5) onto the wire so that the loops points to the right.

Glue the two guides into the two holes drilled in the post and reconnect the wire to the operating arm.

The lamp (part 6) and finial (part 11) can now be glued to the post to complete the main construction.

To fit it to the track side, we recommend that the signal and ladder are mounted on a wooden base approximately 5" x 2", that can then be fixed to the ground beside your railway. Glue a 1/8" diameter rod into the hole in the base of the post and this can be used to mount it to the wooden base. The ladder, which has the two side runners bent in at an angle at the top end, can be glued to the post and the wooden base as required.

Operation.

Most people will use this as a simple semaphore signal and disregard the rear spectacle however, here is a brief description of how it was actually used by the Ffestiniog Railway.

This design of signal was manufactured by McKenzie & Holland and was installed in several positions along the railway around 1878.

When the arm is horizontal (on), the spectacles present a red (stop) light to the front and a green (go) light to the rear.

When the arm is at the 'off' position, pointing down at about 7 o'clock, the front, red spectacle, has moved up and a white light is shown (go). At the rear, the small spectacle had also moved up and presented a white light which, to trains coming in this direction, meant stop.

As the arm moved from on to off, it went through an intermediate position known as 'time', where the front aspect offered a red light and the rear aspect showed no light as the bottom half of the spectacle obscured the light.

From this description, it is clear that at night, when only the lights were visible, the driver had to know if he was looking at the front or rear of the signal to know just what the white light meant.

All sounds very complicated and if you really want to try to understand the signalling system, it is described in detail in 'The Ffestiniog Railway Vol 2' by J. I. C.Boyd.